ABB INDUSTRIAL DRIVES

ACS880 liquid-cooled multidrive cabinets and modules

Electrical planning



ACS880 liquid-cooled multidrive cabinets and modules

Electrical planning

Table of contents



Table of contents

1 Introduction to the manual

Contents of this chapter	9
Applicability	9
Safety instructions	9
Target audience	9
Terms and abbreviations	10
Related documents	11
Cabinet-installed multidrive manuals	11
Multidrive module manuals	11

2 Electrical planning guidelines

Contents of this chapter	13
Limitation of liability	13
Selecting the supply disconnecting device	13
Cabinet-installed multidrives	13
Multidrive modules	13
European Union	13
North America	14
Other regions	14
Selecting the main contactor (breaker)	14
Cabinet-installed multidrives	14
Multidrive modules	14
Selecting the supply transformer	15
Cabinet-installed multidrives	15
Basic guidelines	15
Additional notes	16
Multidrive modules	17
IGBT supply modules ACS880-204LC	17
Diode supply modules ACS880-304LC+A019	17
Examining the compatibility of the motor and drive	18
Protecting the motor insulation and bearings	18
Requirements table	18
Availability of du/dt filter and common mode filter by drive or inverter type	21
Additional requirements for explosion-safe (EX) motors	21
Additional requirements for ABB motors of types other than M2_, M3_, M4_, HX_ and AM_	21
Additional requirements for braking applications	21
Additional requirements for drives with an IGBT supply unit or regenerative rectifier unit	21
Additional requirements for ABB high-output and IP23 motors	21
Additional requirements for non-ABB high-output and IP23 motors	22
Additional note for sine filters	22
Selecting the power cables	23
General guidelines	23
Typical power cable sizes	23



Power cable types	24
Recommended power cable types	24
Alternate power cable types	24
Not allowed power cable types	25
Power cable shield	25
Selecting the control cables	27
Shielding	27
Signals in separate cables	27
Signals that can be run in the same cable	27
Relay cable type	27
Control panel to drive connection	27
Routing the cables	28
General guidelines, IEC	28
Continuous motor cable shield or enclosure for equipment on the motor cable	28
Separate control cable ducts	29
Implementing thermal overload and short circuit protections	30
Protecting the input power cable against thermal overload	30
Diode supply unit	30
IGBT supply unit	30
Protecting the input power cable in short-circuits	30
Diode supply unit	30
IGBT supply unit	30
Protecting the drive against thermal overload	30
Cabinet-installed multidrives	30
Multidrive modules	30
Protecting against short-circuit inside the drive	31
Cabinet-installed multidrives	31
Multidrive modules	31
Protecting the motor and motor cable in short-circuits	31
Protecting the motor cables against thermal overload	31
Protecting the motor against thermal overload	31
Implementing a motor temperature sensor connection	32
Connecting motor temperature sensor to the drive via an option module	32
Connection of motor temperature sensor to the drive via a relay	33
Implementing a ground fault protecting function	34
Cabinet-installed multidrives	34
Residual current device compatibility	34
Multidrives modules	34
Residual current device compatibility	34
Implementing the Emergency stop function	34
Cabinet-installed multidrives	34
Multidrive modules	35
Implementing the Safe torque off function	35
Implementing the Prevention of unexpected start-up function	35
Cabinet-installed multidrives	35
Multidrive modules	35
Implementing the Safely-limited speed function	35
Cabinet-installed multidrives	35
Multidrive modules	36
Implementing the functions provided by the FSO-xx safety functions module	36
Cabinet-installed multidrives	36
Multidrive modules	36



Supplying power for the auxiliary circuits	36
Cabinet-installed multidrives	36
Multidrive modules	36
Using power factor compensation capacitors with the drive	37
Using a safety switch between the drive and the motor	37
Implementing the Power-loss ride-through function	37
Implementing the control of a contactor between drive and motor	37
Implementing a bypass connection	38
Protecting the contacts of relay outputs	38

3 Standards and markings

Contents of this chapter	41
Applicable standards	41
Markings	42
EMC compliance (IEC/EN 61800-3:2004 + A2012)	43
Definitions	43
Category C3	43
Category C4	43
EU Declaration of Conformity (Machinery Directive)	45
Multidrive modules	45
Cabinet-installed multidrives	46
Approvals	46
Disclaimers	47
Generic disclaimer	47
Cybersecurity disclaimer	47

Further information



1

Introduction to the manual

Contents of this chapter

This chapter contains general information of the manual, a list of related manuals, and a list of terms and abbreviations.

Applicability

This manual is applicable with the ACS880 liquid-cooled multidrive cabinets and modules.

Safety instructions



WARNING!

Obey the safety instructions given in *Safety instructions for ACS880 liquid-cooled multidrive cabinets and modules* (3AXD50000048633 [English]). If you ignore the safety instructions, injury or death, or damage to the equipment can occur.

If you are not a qualified electrician, do not do installation or maintenance work.

Target audience

This manual is intended for people who plan electrical installation of the drive. The reader is expected to know the fundamentals of electricity, wiring, electrical components and electrical schematic symbols.

Terms and abbreviations

Term	Description
ACS-AP-x	Assistant control panel
BCU	Type of control unit
BLCL	Series of LCL-filters, for example BLCL-15-5
Brake unit	Brake chopper modules under control of one control board, and related accessories
Cabinet	An enclosure that consists of one or more cubicles
CMF	Common mode filtering
Control board	Circuit board in which the control program runs
Control unit	Control board built in a housing (often rail-mountable)
Cubicle	One section of a cabinet-installed drive. A cubicle is typically behind a door of its own.
DC/DC converter	Charges or discharges an external energy storage (such as a battery or capacitor bank) from or into the DC bus
DC/DC converter module	Converter power electronics, related components and DC capacitors enclosed in a metal frame or enclosure. Intended for cabinet installation.
DC/DC converter unit	DC/DC converter module(s) under control of one control board, and related components
DC link	DC circuit between rectifier and inverter
DDCS	Distributed drives communication system protocol
Diode supply module	Diode rectifier and related components enclosed in a metal frame or enclosure. Intended for cabinet installation.
Diode supply unit	Diode supply modules under control of one control board, and related components.
Drive	Frequency converter for controlling AC motors
EMC	Electromagnetic compatibility
Fieldbus adapter module	Device through which the drive is connected to an external communication network, that is, a fieldbus
FSO-12, FSO-21	Optional functional safety modules
IGBT supply module	IGBT bridge and related components enclosed inside a metal frame or enclosure. Intended for cabinet installation.
IGBT supply unit	IGBT supply module(s) under control of one control board, and related components.
Incoming unit	Part of the cabinet line-up that contains the input power cable terminals. Can also contain switching equipment etc.
Intermediate circuit	DC circuit between rectifier and inverter
Inverter	Converts direct current and voltage to alternating current and voltage.
Inverter module	Inverter bridge, related components and drive DC link capacitors enclosed in a metal frame or enclosure. Intended for cabinet installation.
Inverter unit	Inverter module(s) under control of one control board, and related components. One inverter unit typically controls one motor.
LCL filter	Inductor-capacitor-inductor filter
Multidrive	Drive for controlling several motors which are typically coupled to the same machinery. Includes one supply unit, and one or several inverter units.
Parameter	In the drive control program, user-adjustable operation instruction to the drive, or signal measured or calculated by the drive. In some (for example fieldbus) contexts, a value that can be accessed as an object, eg, variable, constant, or signal.
SIL	Safety integrity level (1...3) (IEC 61508)
Single drive	Drive for controlling one motor
STO	Safe torque off (IEC/EN 61800-5-2)
Supply module	Rectifier bridge and related components enclosed in a metal frame or enclosure. Intended for cabinet installation.
Supply unit	Supply module(s) under control of one control board, and related components.
ZCU	Type of control unit

Related documents

■ Cabinet-installed multidrive manuals

Manual	Code
General manuals	
<i>ACS880 liquid-cooled multidrive cabinets and modules safety instructions</i>	3AXD50000048633
<i>ACS880 liquid-cooled multidrive cabinets and modules electrical planning instructions</i>	3AXD50000048634
<i>ACS880 liquid-cooled multidrive cabinets mechanical installation instructions</i>	3AXD50000048635
<i>CIO-01 I/O module for distributed I/O bus control user's manual</i>	3AXD50000126880
Supply unit manuals	
<i>ACS880-207LC IGBT supply units hardware manual</i>	3AXD50000174782
<i>ACS880 IGBT supply control program firmware manual</i>	3AUA0000131562
Inverter unit manuals	
<i>ACS880-107LC inverter units hardware manual</i>	3AXD50000196111
<i>ACS880 primary control program firmware manual</i>	3AUA0000085967
<i>ACS880 primary control program quick start-up guide</i>	3AUA0000098062
Manuals for application programs (Crane, Winder, etc.)	
Brake unit and DC/DC converter unit manuals	
<i>ACS880-607LC 1-phase brake units hardware manual</i>	3AXD50000481491
<i>ACS880 (3-phase) brake control program firmware manual</i>	3AXD50000020967
<i>ACS880-1607LC DC/DC converter units hardware manual</i>	3AXD50000431342
<i>ACS880 DC/DC converter control program firmware manual</i>	3AXD50000024671
Option manuals	
<i>ACS880-1007LC liquid cooling unit user's manual</i>	3AXD50000129607
<i>ACS880 +C132 marine type-approved cabinet-built drives supplement</i>	3AXD50000039629
<i>ACS-AP-x assistant control panels user's manual</i>	3AUA0000085685
<i>Drive composer start-up and maintenance PC tool user's manual</i>	3AUA0000094606
Manuals for I/O extension modules, fieldbus adapters, safety options etc.	

You can find manuals on the Internet. See www.abb.com/drives/documents. For manuals not available in the document library, contact your local ABB representative.

■ Multidrive module manuals

Manual	Code
General manuals	
<i>ACS880 liquid-cooled multidrive cabinets and modules safety instructions</i>	3AXD50000048633
<i>ACS880 liquid-cooled multidrive cabinets and modules electrical planning instructions</i>	3AXD50000048634
<i>Drive modules cabinet design and construction instructions</i>	3AUA0000107668
<i>BCU-02/12/22 control units hardware manual</i>	3AUA0000113605
<i>CIO-01 I/O module for distributed I/O bus control user's manual</i>	3AXD50000126880
Supply module manuals	
<i>ACS880-204LC IGBT supply modules hardware manual</i>	3AXD50000284436
<i>ACS880 IGBT supply control program firmware manual</i>	3AUA0000131562

12 Introduction to the manual

Manual	Code
<i>ACS880-304LC+A019 diode supply modules hardware manual</i>	3AXD50000045157
<i>ACS880 diode supply control program firmware manual</i>	3AUA0000103295
Inverter module manuals and guides	
<i>ACS880-104LC inverter modules hardware manual</i>	3AXD50000045610
<i>ACS880 primary control program firmware manual</i>	3AUA0000085967
<i>ACS880 primary control program quick start-up guide</i>	3AUA0000098062
Brake module and DC/DC converter module manuals	
<i>ACS880-604LC 1-phase brake chopper modules hardware manual</i>	3AXD50000184378
<i>ACS880-1604LC DC/DC converter modules hardware manual</i>	3AXD50000371631
<i>ACS880 DC/DC converter control program firmware manual</i>	3AXD50000024671
Option manuals	
<i>ACS880 +C132 marine type-approved drive modules and module packages supplement</i>	3AXD50000037752
<i>ACS880-1007LC liquid cooling unit user's manual</i>	3AXD50000129607
<i>ACX-AP-x assistant control panels user's manual</i>	3AUA0000085685
<i>BAMU-12C auxiliary measurement unit hardware manual</i>	3AXD50000117840
<i>Drive composer start-up and maintenance PC tool user's manual</i>	3AUA0000094606
<i>Drive application programming (IEC 61131-3) manual</i>	3AUA0000127808
Manuals and quick guides for I/O extension modules, fieldbus adapters, safety functions modules, etc.	

See www.abb.com/drives/documents for all manuals on the Internet.

You can find all documentation related to the multidrive modules on the Internet at <https://sites-apps.abb.com/sites/lvacdrivesengineeringsupport/content>.

2

Electrical planning guidelines

Contents of this chapter

This chapter contains guidelines for planning the electrical installation of the drive.

Limitation of liability

The installation must always be designed and made according to applicable local laws and regulations. ABB does not assume any liability whatsoever for any installation which breaches the local laws and/or other regulations. Furthermore, if the recommendations given by ABB are not followed, the drive may experience problems that the warranty does not cover.

Selecting the supply disconnecting device

■ Cabinet-installed multidrives

The drive is equipped with a main disconnecting device as standard. Depending on the size of the drive, and the selected options, the type of disconnecting device may vary. Examples: switch-disconnector, withdrawable air circuit breaker, etc.

■ Multidrive modules

You must equip the drive with a main supply disconnecting device which meets the local safety regulations. You must be able to lock the disconnecting device to the open position for installation and maintenance work.

European Union

To meet the European Union Directives, according to standard EN 60204-1, Safety of Machinery, the disconnecting device must be one of the following types:

- switch-disconnector, with or without fuses, in accordance with IEC 60947-3, utilization category AC-23B or DC-23B
- disconnector that has an auxiliary contact that in all cases causes switching devices to break the load circuit before the opening of the main contacts of the disconnector (EN 60947-3)
- a circuit-breaker suitable for isolation in accordance with IEC 60947-2.

North America

Installations must meet the requirements of UL (UL 508C) and/or CSA C22.2 No. 14 and be compliant with NFPA 70 (NEC) and/or Canadian Electrical Code (CE) along with state and local codes for your location and application. (NFPA 70 (NEC) = National Fire Protection Association 70 (National Electric Code).

Other regions

The disconnecting device must conform to the applicable local safety regulations.

Selecting the main contactor (breaker)

■ **Cabinet-installed multidrives**

Depending on the drive size, you can order it either with a main contactor (option +F250), or a main breaker (option +F255).

■ **Multidrive modules**

You can order a pre-selected main contactor (breaker) from ABB. See the appropriate drive or supply module hardware manual.

Obey these guidelines when you select a customer-defined main contactor:

- Dimension the contactor according to the nominal voltage and current of the drive. Also consider the environmental conditions such as ambient temperature.
 - Select contactor with utilization category AC-1 (number of operations under load) according to IEC 60947-4, Low-voltage switch gear and control gear.
 - Consider the application life time requirements.
-

Selecting the supply transformer

■ Cabinet-installed multidrives

Basic guidelines

1. Define the apparent power of the transformer:
 - if the drive is equipped with a diode supply unit, use this equation:
 $S_N \text{ (kVA)} = 1.32 \times \text{sum of the motor shaft powers (kW)}$
 - if the drive is equipped with an IGBT supply unit, use this equation:
 $S_N \text{ (kVA)} = 1.16 \times \text{sum of the motor shaft powers (kW)}$
 2. Define the nominal voltage for the transformer secondary winding according to the nominal input voltage of the drive. See the supply unit hardware manual.
 3. Make sure that the transformer complies with the electrical power network specification of the drive. See the appropriate drive or supply unit hardware manual for:
 - nominal input voltage, allowed voltage variation and imbalance
 - nominal frequency and allowed variation
 - short-circuit withstand strength (IEC), or short-circuit current protection (UL or CSA)
 - etc.
 4. Consider the additional notes below.
 5. Contact the transformer manufacturer for more information on the transformer selection.
-

Additional notes

A drive larger than 500 kVA with an IGBT supply unit

Use a two-winding transformer dedicated to drives and motors. Alternatively, use a three-winding transformer, and connect only drives and motors to the same secondary winding.



WARNING!

Do not connect capacitive load (for example: lighting, PCs, PLCs, small power factor compensation capacitors, etc.), to the same transformer secondary winding with drive. It can cause current resonances which can damage the equipment.

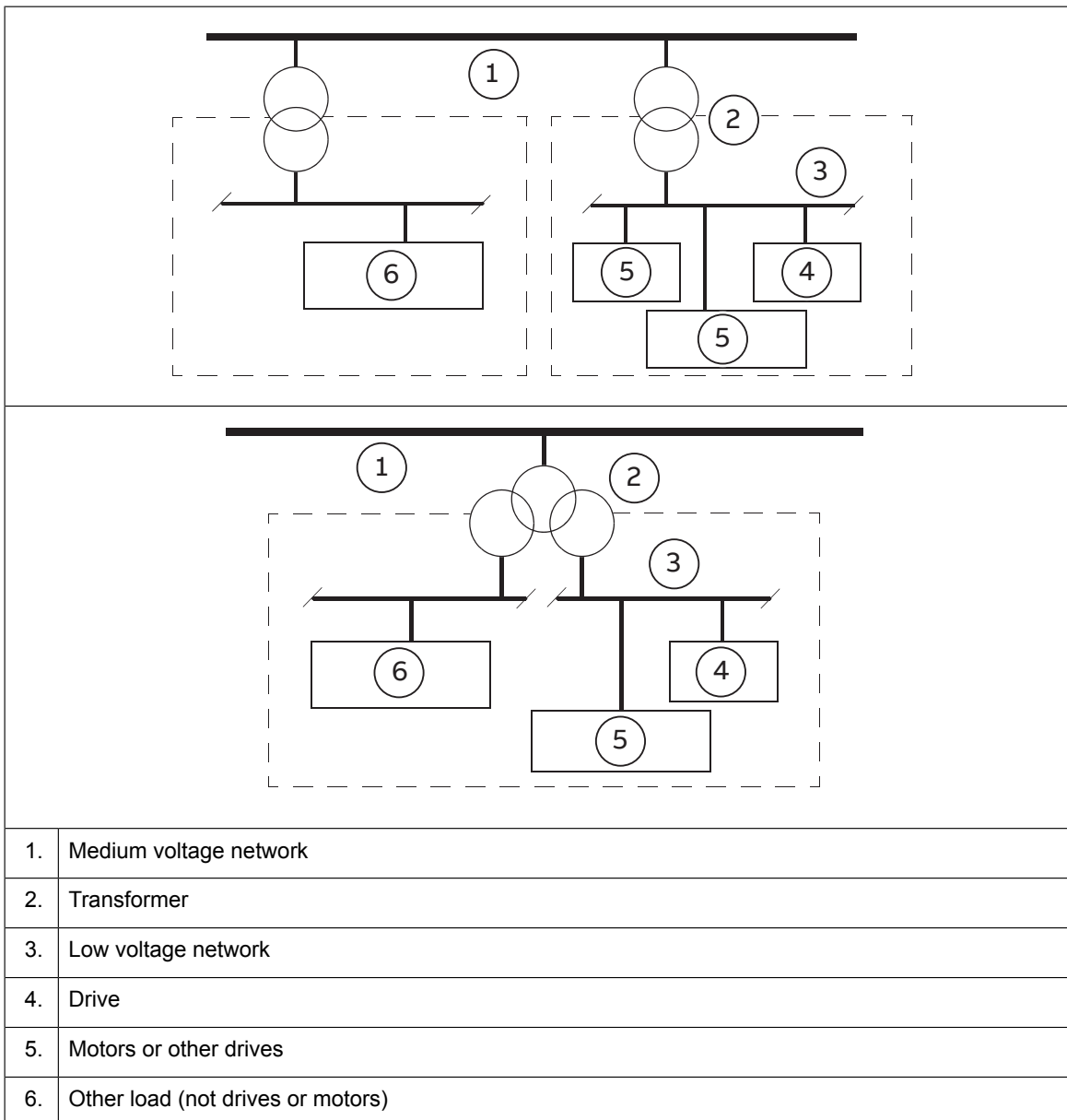

Two parallel-connected supply units

See the appropriate supplement for the parallel-connected supply units, or contact ABB for instructions in selecting the transformer(s).

■ **Multidrive modules**

IGBT supply modules ACS880-204LC

See the instructions given for the cabinet-installed multidrives.

Diode supply modules ACS880-304LC+A019

The supply modules do not have input chokes. For this reason, dimension the supply transformer according to the supply unit apparent power (S_n), and make sure that the supply transformer impedance is suitable for the supply unit. The transformer reactance X_k has to be at least 4% and the transformer nominal apparent power (S_n) must not be more than 2 times the nominal apparent power (S_n) of the supply unit in question.

Examining the compatibility of the motor and drive

Use asynchronous AC induction motors, permanent magnet synchronous motors, AC induction servomotors or ABB synchronous reluctance motors (SynRM motors) with the drive.

Select the motor size and drive type from the rating table on basis of the AC line voltage and motor load. You can find the rating table in the appropriate drive or inverter unit hardware manual. You can also use the DriveSize PC tool.

Make sure that the motor withstands the maximum peak voltage in the motor terminals. See [Requirements table \(page 18\)](#). For basics of protecting the motor insulation and bearings in drive systems, see [Protecting the motor insulation and bearings \(page 18\)](#).

Note:

- Consult the motor manufacturer before using a motor whose nominal voltage differs from the AC line voltage connected to the drive input.
- The voltage peaks at the motor terminals are relative to the supply voltage of the drive, not the drive output voltage.
- If the motor and drive are not of the same size, consider the operation limits of the drive control program for the motor nominal voltage and current. See the appropriate parameters in the firmware manual.

■ Protecting the motor insulation and bearings

The drive employs modern IGBT inverter technology. Regardless of frequency, the drive output comprises pulses of approximately the drive DC bus voltage with a very short rise time. The pulse voltage can almost double at the motor terminals, depending on the attenuation and reflection properties of the motor cable and the terminals. This can cause additional stress on the motor and motor cable insulation.

Modern variable speed drives with their fast rising voltage pulses and high switching frequencies can generate current pulses that flow through the motor bearings. This can gradually erode the bearing races and rolling elements.

du/dt filters protect motor insulation system and reduce bearing currents. Common mode filters mainly reduce bearing currents. Insulated N-end (non-drive end) bearings protect the motor bearings.

■ Requirements table

These tables show how to select the motor insulation system and when a drive du/dt and common mode filters and insulated N-end (non-drive end) motor bearings are required. Ignoring the requirements or improper installation may shorten motor life or damage the motor bearings and voids the warranty.

This table shows the requirements when an ABB motor is in use.

Motor type	Nominal AC supply voltage	Requirement for			
		Motor insulation system	ABB du/dt and common mode filters, insulated N-end motor bearings		
			$P_N < 100$ kW and frame size < IEC 315	$100 \text{ kW} \leq P_N < 350$ kW or IEC 315 \leq frame size < IEC 400	$P_N \geq 350$ kW or frame size \geq IEC 400
			$P_N < 134$ hp and frame size < NEMA 500	$134 \text{ hp} \leq P_N < 469$ hp or NEMA 500 \leq frame size \leq NEMA 580	$P_N \geq 469$ hp or frame size > NEMA 580
Random-wound M2_, M3_ and M4_	$U_N \leq 500$ V	Standard	-	+ N	+ N + CMF
	$500 \text{ V} < U_N \leq 600$ V	Standard	+ du/dt	+ N + du/dt	+ N + du/dt + CMF
		or Reinforced	-	+ N	+ N + CMF
	$600 \text{ V} < U_N \leq 690$ V (cable length \leq 150 m)	Reinforced	+ du/dt	+ N + du/dt	+ N + du/dt + CMF
	$600 \text{ V} < U_N \leq 690$ V (cable length > 150 m)	Reinforced	-	+ N	+ N + CMF
Form-wound HX_ and AM_	$380 \text{ V} < U_N \leq 690$ V	Standard	n.a.	+ N + CMF	$P_N < 500$ kW: +N + CMF
					$P_N \geq 500$ kW: +N + du/dt + CMF
Old 1) form-wound HX_ and modular	$380 \text{ V} < U_N \leq 690$ V	Check with the motor manufacturer.	+ N + du/dt with voltages over 500 V + CMF		
Random-wound HX_ and AM_ 2)	$0 \text{ V} < U_N \leq 500$ V	Enamelled wire with fiber glass taping	+ N + CMF		
	$500 \text{ V} < U_N \leq 690$ V		+ N + du/dt + CMF		
HDP	Consult the motor manufacturer.				

1) manufactured before 1.1.1998

2) For motors manufactured before 1.1.1998, check for additional instructions with the motor manufacturer.

This table shows the requirements when a non-ABB motor is in use.

Motor type	Nominal AC supply voltage	Requirement for			
		Motor insulation system	ABB du/dt and common mode filters, insulated N-end motor bearings		
			$P_N < 100 \text{ kW}$ and frame size < IEC 315	$100 \text{ kW} \leq P_N < 350 \text{ kW}$ or IEC 315 \leq frame size < IEC 400	$P_N \geq 350 \text{ kW}$ or frame size \geq IEC 400
			$P_N < 134 \text{ hp}$ and frame size < NEMA 500	$134 \text{ hp} \leq P_N < 469 \text{ hp}$ or NEMA 500 \leq frame size \leq NEMA 580	$P_N \geq 469 \text{ hp}$ or frame size > NEMA 580
Random-wound and form-wound	$U_N \leq 420 \text{ V}$	Standard: $\hat{U}_{LL} = 1300 \text{ V}$	-	+ N or CMF	+ N + CMF
	$420 \text{ V} < U_N \leq 500 \text{ V}$	Standard: $\hat{U}_{LL} = 1300 \text{ V}$	+ du/dt	+ du/dt + (N or CMF)	+ N + du/dt + CMF
		or	Reinforced: $\hat{U}_{LL} = 1600 \text{ V}$, 0.2 micro-second rise time	-	+ N or CMF
	$500 \text{ V} < U_N \leq 600 \text{ V}$	Reinforced: $\hat{U}_{LL} = 1600 \text{ V}$	+ du/dt	+ du/dt + (N or CMF)	+ N + du/dt + CMF
		or	Reinforced: $\hat{U}_{LL} = 1800 \text{ V}$	-	+ N or CMF
	$600 \text{ V} < U_N \leq 690 \text{ V}$	Reinforced: $\hat{U}_{LL} = 1800 \text{ V}$	+ du/dt	+ du/dt + N	+ N + du/dt + CMF
		Reinforced: $\hat{U}_{LL} = 2000 \text{ V}$, 0.3 micro-second rise time ¹⁾	-	+ N + CMF	+ N + CMF

¹⁾ If the intermediate DC circuit voltage of the drive is increased from the nominal level due to long term resistor braking cycles, check with the motor manufacturer if additional output filters are needed in the applied drive operation range.

The abbreviations used in the tables are defined below.

Abbr.	Definition
U_N	Nominal AC line voltage
\hat{U}_{LL}	Peak line-to-line voltage at motor terminals which the motor insulation must withstand
P_N	Motor nominal power
du/dt	du/dt filter at the output of the drive
CMF	Common mode filter
N	N-end bearing: insulated motor non-drive end bearing
n.a.	Motors of this power range are not available as standard units. Consult the motor manufacturer.

Availability of du/dt filter and common mode filter by drive or inverter type

Product type	Availability of du/dt filter	Availability of common mode filter (CMF)
ACS880-104LC	Standard	Standard
ACS880-107LC	Standard	Standard

Additional requirements for explosion-safe (EX) motors

If you will use an explosion-safe (EX) motor, follow the rules in the requirements table above. In addition, consult the motor manufacturer for any further requirements.

Additional requirements for ABB motors of types other than M2_, M3_, M4_, HX_ and AM_

Use the selection criteria given for non-ABB motors.

Additional requirements for braking applications

When the motor brakes the machinery, the intermediate circuit DC voltage of the drive increases, the effect being similar to increasing the motor supply voltage by up to 20 percent. Consider this voltage increase when specifying the motor insulation requirements if the motor will be braking a large part of its operation time.

Example: Motor insulation requirement for a 400 V AC line voltage application must be selected as if the drive were supplied with 480 V.

Additional requirements for drives with an IGBT supply unit or regenerative rectifier unit

It is possible to increase the intermediate circuit DC voltage from the nominal (standard) level with a parameter in the supply unit control program. If you choose to do this, select the motor insulation system which withstands the increased DC voltage level.

Additional requirements for ABB high-output and IP23 motors

The rated output power of high output motors is higher than what is stated for the particular frame size in EN 50347 (2001).

This table shows the requirements for protecting the motor insulation and bearings in drive systems for ABB random-wound motor series (for example, M3AA, M3AP and M3BP).

Nominal AC supply voltage	Requirement for			
	Motor insulation system	ABB du/dt and common mode filters, insulated N-end motor bearings		
		$P_N < 100 \text{ kW}$	$100 \text{ kW} \leq P_N < 200 \text{ kW}$	$P_N \geq 200 \text{ kW}$
		$P_N < 140 \text{ hp}$	$140 \text{ hp} \leq P_N < 268 \text{ hp}$	$P_N \geq 268 \text{ hp}$
$U_N \leq 500 \text{ V}$	Standard	-	+ N	+ N + CMF
$500 \text{ V} < U_N \leq 600 \text{ V}$	Standard	+ du/dt	+ du/dt + N	+ du/dt + N + CMF
	or Reinforced	-	+ N	+ N + CMF
$600 \text{ V} < U_N \leq 690 \text{ V}$	Reinforced	+ du/dt	+ du/dt + N	+ du/dt + N + CMF

Additional requirements for non-ABB high-output and IP23 motors

The rated output power of high-output motors is higher than what is stated for the particular frame size in EN 50347 (2001).

If you plan to use a non-ABB high-output motor or an IP23 motor, consider these additional requirements for protecting the motor insulation and bearings in drive systems:

- If motor power is below 350 kW: Equip the drive and/or motor with the filters and/or bearings according to the table below.
- If motor power is above 350 kW: Consult the motor manufacturer.

Nominal AC supply voltage	Requirement for		
	Motor insulation system	ABB du/dt and common mode filters, insulated N-end motor bearings	
		$P_N < 100$ kW or frame size < IEC 315	100 kW < $P_N < 350$ kW or IEC 315 < frame size < IEC 400
	$P_N < 134$ hp or frame size < NEMA 500	134 hp < $P_N < 469$ hp or NEMA 500 < frame size < NEMA 580	
$U_N \leq 500$ V	Standard: $\hat{U}_{LL} = 1300$ V	+ N or CMF	+ N or CMF
420 V < $U_N < 500$ V	Standard: $\hat{U}_{LL} = 1300$ V	+ du/dt + (N or CMF)	+ N + du/dt + CMF
	or Reinforced: $\hat{U}_{LL} = 1600$ V, 0.2 microsecond rise time	+ N or CMF	+ N or CMF
500 V < $U_N \leq 600$ V	Reinforced: $\hat{U}_{LL} = 1600$ V	+ du/dt + (N or CMF)	+ N + du/dt + CMF
	or Reinforced: $\hat{U}_{LL} = 1800$ V	+ N or CMF	+ N + CMF
600 V < $U_N \leq 690$ V	Reinforced: $\hat{U}_{LL} = 1800$ V	+ N + du/dt	+ N + du/dt + CMF
	Reinforced: $\hat{U}_{LL} = 2000$ V, 0.3 microsecond rise time ¹⁾	+ N + CMF	+ N + CMF

¹⁾ If the intermediate DC circuit voltage of the drive is increased from the nominal level due to long term resistor braking cycles, check with the motor manufacturer if additional output filters are needed in the applied drive operation range.

Additional note for sine filters

A sine filter also protects the motor insulation system. The peak phase-to-phase voltage with a sine filter is approximately $1.5 \cdot U_N$. Check the availability of the sine filter from ABB.

Selecting the power cables

ACS880-304LC +A019 diode supply modules: Obey the power cable selection instructions in *ACS880-304LC+A019 diode supply modules hardware manual (3AXD50000045157 (English))*.

■ General guidelines

Select the input power and motor cables according to local regulations.

- **Current:** Select a cable capable of carrying the drive (or motor) nominal current.
- **Temperature:** For IEC, select a cable rated for at least 70 °C (90 °C for IP55 [UL Type 12]) maximum permissible temperature of conductor in continuous use. For North America, power cables must be rated for 90 °C (194 °F) or higher with derating.
- **Voltage:** 600 V AC cable is accepted for up to 500 V AC. 750 V AC cable is accepted for up to 600 V AC. 1000 V AC cable is accepted for up to 690 V AC.

Use symmetrical shielded power cables. They reduce electromagnetic emissions of the whole drive system as well as the stress on motor insulation, bearing currents and wear. To comply with the European EMC requirements, use a preferred cable type. See [Recommended power cable types \(page 24\)](#).

If the cabling is in a metal conduit, it reduces the electromagnetic emission of the whole drive system.

The protective conductor must always have an adequate conductivity. Unless local wiring regulations state otherwise, the cross-sectional area of the protective conductor must agree with the conditions that require automatic disconnection of the supply required in 411.3.2. of IEC 60364-4-41:2005 and be capable of withstanding the prospective fault current during the disconnection time of the protective device. The cross-sectional area of the protective conductor can either be selected from the table below or calculated according to 543.1 of IEC 60364-5-54.

This table shows the minimum cross-sectional area of the protective conductor related to the phase conductor size according to IEC 61800-5-1 when the phase conductor and the protective conductor are made of the same metal. If this is not so, the cross-sectional area of the protective earthing conductor shall be determined in a manner which produces a conductance equivalent to that which results from the application of this table.

Cross-sectional area of the phase conductors S (mm ²)	Minimum cross-sectional area of the corresponding protective conductor S_p (mm ²)
$S \leq 16$	$S^{1), 2)}$
$16 < S \leq 35$	16
$35 < S$	$S/2$

1) Drive safety standard IEC/EN 61800-5-1:

- use a protective earth conductor with a cross-section of at least 10 mm² (8 AWG) Cu or 16 mm² (6 AWG) Al, or
- use a second protective earth conductor of the same cross-sectional area as the original protective earthing conductor, or
- use a device which automatically disconnects the supply if the protective earth conductor breaks.

2) Drive safety standard IEC/EN 61800-5-1: If the protective earth conductor is separate (ie, it does not form part of the input power cable or the input power cable enclosure), the cross section must be at least:

- 2.5 mm² (14 AWG) when the conductor is mechanically protected, or
- 4 mm² (12 AWG) when the conductor is not mechanically protected.

■ Typical power cable sizes

See the technical data of the drive (or unit).

■ **Power cable types**

Recommended power cable types

This section presents the recommended cable types. Check with local / state / country electrical codes for allowance.

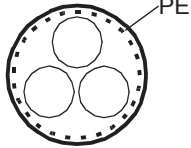
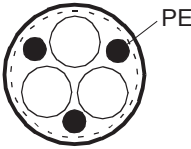
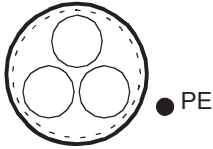

Cable type	Use as input power cabling	Use as motor cabling
 <p>Symmetrical shielded (or armored) cable with three phase conductors and concentric PE conductor as shield (or armor)</p>	Yes	Yes
 <p>Symmetrical shielded (or armored) cable with three phase conductors and symmetrically constructed PE conductor and a shield (or armor)</p>	Yes	Yes
 <p>Symmetrical shielded (or armored) cable with three phase conductors and a shield (or armor), and separate PE conductor/cable¹⁾</p>	Yes	Yes

¹⁾ A separate PE conductor is required if the conductivity of the shield (or armor) is not sufficient for the PE use.

Alternate power cable types

Exception for ACS880-304LC +A019 diode supply modules: These power cable types are not allowed.

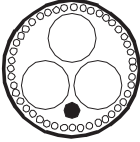
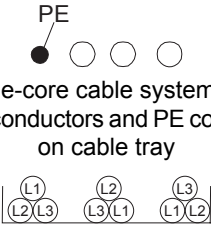
Cable type	Use as input power cabling	Use as motor cabling
 <p>Four-conductor cabling in metal conduit (three phase conductors and PE), eg, EMT, or four-conductor armored cable</p>	Yes	Yes with phase conductor smaller than 10 mm ² (8 AWG) or motors up to 30 kW (40 hp)

Cable type	Use as input power cabling	Use as motor cabling
 <p>Well-shielded (Al/Cu shield or armor) four-conductor cable (three phase conductors and a PE)</p>	Yes	Yes with motors up to 100 kW (135 hp). A potential equalization between the frames of motor and driven equipment is required.
 <p>A single-core cable system: three phase conductors and PE conductor on cable tray</p> <p>Preferable cable arrangement to avoid voltage or current unbalance between the phases</p>	Yes  WARNING! If you use unshielded single-core cables in an IT network, make sure that the non-conductive outer sheath (jacket) of the cables have good contact with a properly grounded conductive surface. For example, install the cables on a properly grounded cable tray. Otherwise voltage may become present on the non-conductive outer sheath of the cables, and there is even a risk of an electric shock.	No

Not allowed power cable types

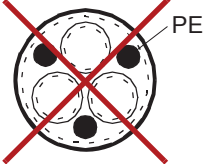
Cable type	Use as input power cabling	Use as motor cabling
 <p>Symmetrical shielded cable with individual shields for each phase conductor</p>	No	No

■ **Power cable shield**

If the cable shield is used as the sole protective earth (PE) conductor, make sure that its conductivity agrees with the PE conductor requirements.

To effectively suppress radiated and conducted radio-frequency emissions, the cable shield conductivity must be at least 1/10 of the phase conductor conductivity. The requirements are easily met with a copper or aluminum shield. The minimum requirement of the motor cable shield of the drive is shown below. It consists of a concentric layer of copper wires with an open helix of copper tape or copper wire. The better and tighter the shield, the lower the emission level and bearing currents.

26 Electrical planning guidelines

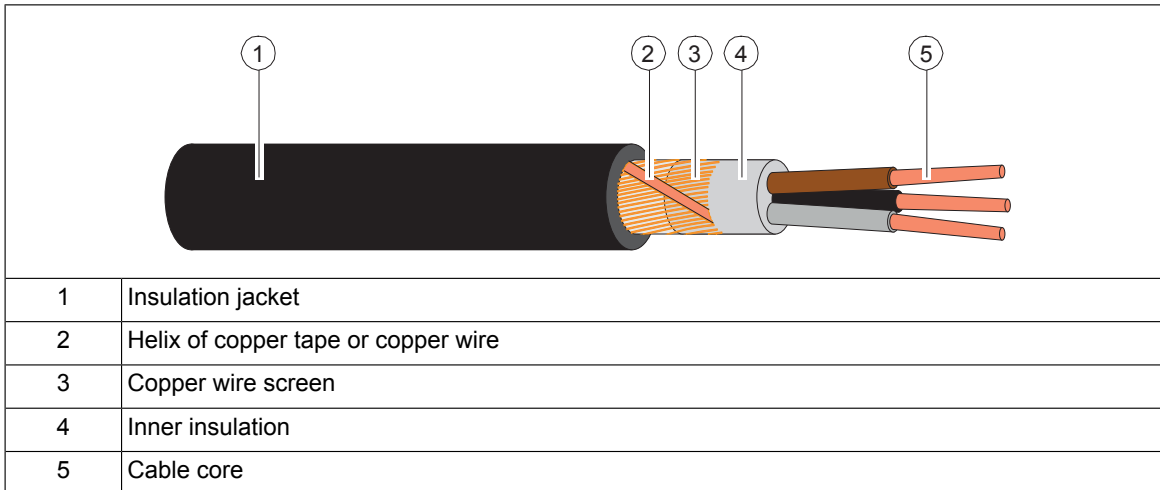

Selecting the control cables

■ Shielding

Only use shielded control cables.

Use a double-shielded twisted pair cable for analog signals. This type of cable is recommended for the pulse encoder signals also. Employ one individually shielded pair for each signal. Do not use common return for different analog signals.

A double-shielded cable (figure a below) is the best alternative for low-voltage digital signals but single-shielded (b) twisted pair cable is also acceptable.

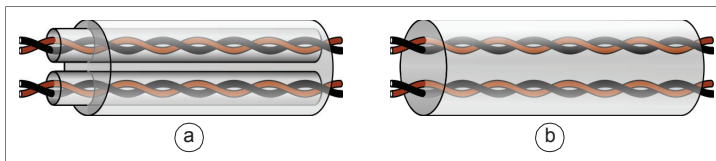

■ Signals in separate cables

Run analog and digital signals in separate, shielded cables. Do not mix 24 V DC and 115/230 V AC signals in the same cable.

■ Signals that can be run in the same cable

If their voltage does not exceed 48 V, relay-controlled signals can be run in the same cables as digital input signals. The relay-controlled signals should be run as twisted pairs.

■ Relay cable type

The cable type with braided metallic screen (for example ÖLFLEX by LAPPKABEL, Germany) has been tested and approved by ABB.

■ Control panel to drive connection

Use EIA-485 with male RJ-45 connector, cable type Cat 5e or better. The maximum permitted length of the cable is 100 m (328 ft).

Routing the cables

■ General guidelines, IEC

- Route the motor cable away from other cables. Motor cables of several drives can be run in parallel installed next to each other.
- Install the motor cable, input power cable and control cables on separate trays.
- Avoid long parallel runs of motor cables with other cables in order to decrease electromagnetic interference caused by the rapid changes in the drive output voltage.
- Where control cables must cross power cables, make sure they are arranged at an angle as near to 90 degrees as possible.
- Do not run extra cables through the drive.
- Make sure that the cable trays have good electrical bonding to each other and to the grounding electrodes. Aluminum tray systems can be used to improve local equalizing of potential.

This figure illustrates the cable routing guidelines with an example drive.

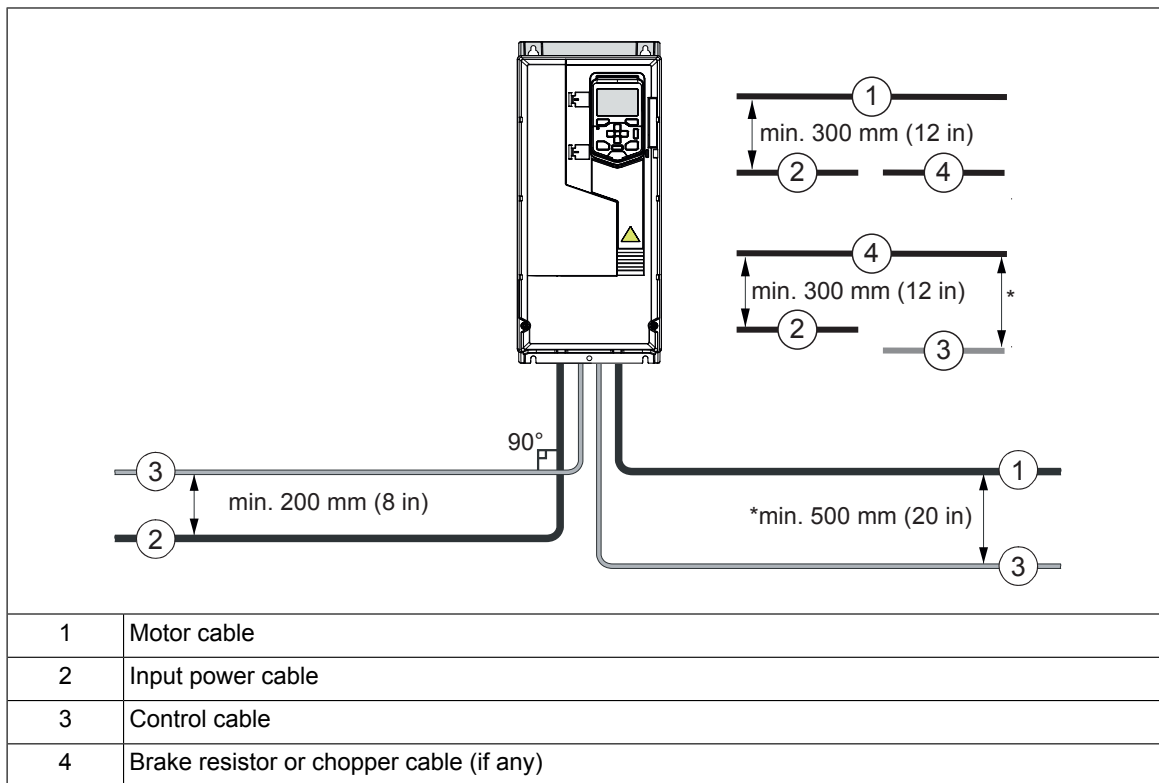

■ Continuous motor cable shield or enclosure for equipment on the motor cable

To minimize the emission level when safety switches, contactors, connection boxes or similar equipment are installed on the motor cable between the drive and the motor:

- Install the equipment in a metal enclosure.
- Use either a symmetrical shielded cable (preferred alternative), or install the cabling in a metal conduit.
- Make sure that there is a good and continuous galvanic connection in the shield/conduit between drive and motor.
- Connect the shield/conduit to the protective ground terminal of the drive and the motor.

■ **Separate control cable ducts**

Lead 24 V DC and 230 V AC (120 V AC) control cables in separate ducts unless the 24 V DC cable is insulated for 230 V AC (120 V AC) or insulated with an insulation sleeving for 230 V AC (120 V AC).

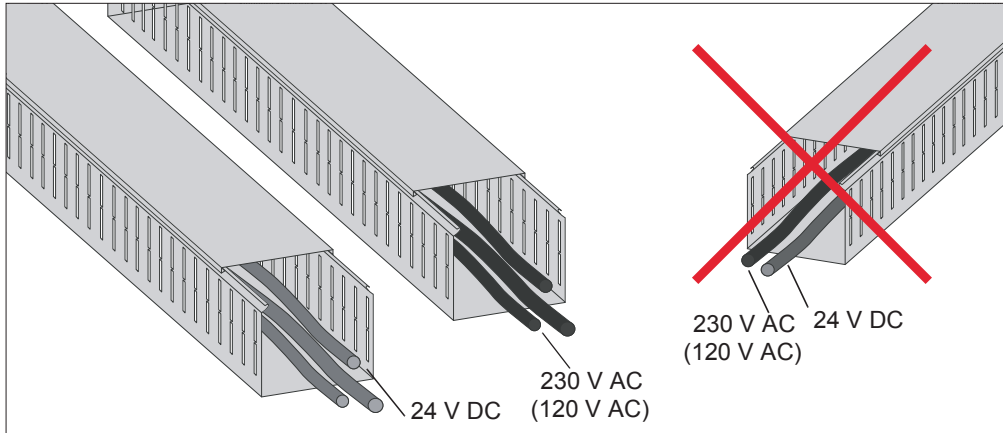

Implementing thermal overload and short circuit protections

■ Protecting the input power cable against thermal overload

Diode supply unit

Equip the input cable with fuses or circuit breaker to protect the cable in a short circuit, and against thermal overload. Obey the local regulations when selecting the protection.



WARNING!

If you use parallel cables, make sure that each conductor is protected individually.

IGBT supply unit

If the cables are dimensioned according to the nominal current of the drive, the drive thermal overload protection protects also the input power cables against thermal overload. No additional thermal protection devices are needed.

■ Protecting the input power cable in short-circuits

Diode supply unit

Equip the input cable with fuses or circuit breaker to protect the cable in a short circuit, and against thermal overload. Obey the local regulations when selecting the protection.



WARNING!

If you use parallel cables, make sure that each conductor is protected individually.

IGBT supply unit

Equip the input power cable with fuses or a circuit breaker to protect the cable in a short-circuit situation. Select the fuses according to the short-circuit strength of the cable, and its supports, etc.

■ Protecting the drive against thermal overload

Cabinet-installed multidrives

The drive is equipped with thermal overload protection as standard. No additional protection devices are needed.

Multidrive modules

Drive with a diode supply unit

Equip the diode supply unit with the ABB-specified input fuses for the thermal overload protection and short circuit protection. See the diode supply module hardware manual.

The inverter units protects themselves against thermal overload. No additional thermal overload protection devices are needed.

Drive with an IGBT supply unit

The supply unit protects itself against thermal overload. No additional thermal overload protection devices are needed.

The inverter units protects themselves against thermal overload. No additional thermal overload protection devices are needed.

■ Protecting against short-circuit inside the drive

Cabinet-installed multidrives

The drive is equipped with input fuses that restrict the drive damage and prevent damage to adjoining equipment in case of a short-circuit inside the drive.

Multidrive modules

Equip the drive with input fuses listed in the technical data of the appropriate supply unit hardware manual. Fuses restrict the drive damage and prevent damage to adjoining equipment in case of a short-circuit inside the drive.

■ Protecting the motor and motor cable in short-circuits

The drive protects the motor cable and motor in a short-circuit situation when the motor cable is sized according to the nominal current of the drive. No additional protection devices are needed.

■ Protecting the motor cables against thermal overload

The drive protects the motor cables against thermal overload when the cables are sized according to the nominal output current of the drive (single drive) or inverter (multidrive). No additional thermal protection devices are needed.



WARNING!

If the drive (single drive) or inverter (multidrive) is connected to multiple motors, use a separate circuit breaker or fuses for protecting each motor cable and motor against overload. The overload protection of the drive (single drive) or inverter (multidrive) is tuned for the total motor load. It may not detect an overload in one motor circuit only.

■ Protecting the motor against thermal overload

According to regulations, the motor must be protected against thermal overload and the current must be switched off when overload is detected. The drive includes a motor thermal protection function that protects the motor and switches off the current when necessary. Depending on a drive parameter value, the function either monitors a calculated temperature value (based on a motor thermal model) or an actual temperature indication given by motor temperature sensors.

The motor thermal protection model supports thermal memory retention and speed sensitivity. The user can tune the thermal model further by feeding in additional motor and load data.

The most common temperature sensors are:

- motor sizes IEC180...225: thermal switch, for example Klixon
- motor sizes IEC200...250 and larger: PTC or Pt100.

See the firmware manual for more information on the motor thermal protection.

Implementing a motor temperature sensor connection



WARNING!

IEC 60664 and IEC 61800-5-1 require double or reinforced insulation between live parts and the surface of accessible parts of electrical equipment which are either non-conductive or conductive but not connected to the protective earth.

You have four implementation alternatives:

1. If there is double or reinforced insulation between the sensor and the live parts of the motor, you can connect the sensor directly to the analog/digital input(s) of the drive.
2. If there is basic insulation between the sensor and the live parts of the motor, you can connect the sensor to the analog/digital input(s) of the drive if all other circuits connected to the digital and analog inputs (typically extra-low voltage circuits) are protected against contact and insulated with basic insulation from other low-voltage circuits. The insulation must be rated for the same voltage level as the drive main circuit. Note that extra-low voltage circuits (such as 24 V DC) typically do not meet these requirements.
Alternative: You can connect the sensor with a basic insulation to the analog/digital input(s) of the drive if you do not connect any other external control circuits to drive digital and analog inputs.
3. You can connect the sensor to the drive via an option module. The sensor and the module must form a reinforced insulation between the motor live parts and the drive control unit. See [Connecting motor temperature sensor to the drive via an option module \(page 32\)](#).
4. You can connect a sensor to a digital input of the drive via an external relay. The insulation of the relay must be rated for the main circuit voltage of the motor. See [Connection of motor temperature sensor to the drive via a relay \(page 33\)](#).

■ Connecting motor temperature sensor to the drive via an option module

This table shows:

- the option module types that you can use for the motor temperature sensor connection
 - the insulation or isolation level that each option module forms between its temperature sensor connector and other connectors
 - the temperature sensor types that you can connect to each option module
 - the temperature sensor insulation requirement in order to form, together with the insulation of the option module, a reinforced insulation between the motor live parts and the drive control unit.
-

Option module		Temperature sensor type			Temperature sensor insulation requirement
Type	Insulation/Isolation	PTC	KTY	Pt100, Pt1000	
FIO-11	Galvanic isolation between sensor connector and other connectors (including drive control unit connector)	-	x	x	Reinforced insulation
FEN-xx	Galvanic isolation between sensor connector and other connectors (including drive control unit connector)	x	x	-	Reinforced insulation
FAIO-01	Basic insulation between sensor connector and drive control unit connector. No insulation between sensor connector and other I/O connectors.	x	x	x	Basic insulation. Connectors of option module other than sensor connector must be left unconnected.
FPTC-xx ¹⁾	Reinforced insulation between sensor connector and other connectors (including drive control unit connector).	x	-	-	No special requirement

¹⁾ Suitable for use in safety functions (SIL2 / PL c rated).

■ Connection of motor temperature sensor to the drive via a relay

PTC alternative A: This table shows the insulation requirement for a customer's external relay, and the insulation requirement for the sensor to fulfill decisive voltage class A (double insulation) of IEC 60800-5-1. The table also shows the insulation of the factory-installed relay (plus code option for a cabinet-installed drive), and the insulation requirement for the sensor.

PTC relay		Temperature sensor insulation requirement
Type	Insulation	
External relay	Basic insulation 6 kV	Basic insulation
Drive options +L505 and +L513	Basic insulation 6 kV	Basic insulation

PTC alternative B: Decisive voltage class B of IEC 60800-5-1 (basic insulation) is provided with a 6 kV relay. Circuits connected to all motor protection relay inputs and outputs must be protected against direct contact.

Pt100 alternative A: This table shows the insulation requirement for a customer's external relay, and the insulation requirement for the sensor to fulfill decisive voltage class A (double insulation) of IEC 60800-5-1. The table also shows the insulation of the factory-installed relay (plus code option for a cabinet-installed drive), and the insulation requirement for the sensor.

Pt100 relay		Temperature sensor insulation requirement
Type	Insulation	
External relay	Basic insulation 6 kV	Basic insulation
Drive options +L506 and +L514	Basic insulation < 6 kV	Double or reinforced insulation

Pt100 alternative B: Decisive voltage class B of IEC 60800-5-1 (basic insulation) can be achieved when there is basic insulation between the sensor and live parts of the motor.

Circuits connected to all motor protection relay inputs and outputs must be protected against direct contact.

Implementing a ground fault protecting function

■ Cabinet-installed multidrives

The drive is equipped with an internal ground fault protective function to protect the unit against ground faults in the motor and motor cable. This function is not a personnel safety or a fire protection feature. See the firmware manual for more information.

An optional ground fault monitoring device (+Q953) is available for TN (grounded) systems. The option includes a ground fault indicator on the drive cabinet door. An optional ground fault monitoring device (+Q954) is available for IT (ungrounded) systems. The option includes a ground fault indicator on the drive cabinet door.

Residual current device compatibility

The drive is suitable to be used with residual current devices of Type B.

Note:

As standard, the drive contains capacitors connected between the main circuit and the frame. These capacitors and long motor cables increase the ground leakage current and may cause nuisance faults in circuit breakers.

■ Multidrives modules

The drive is equipped with an internal ground fault protective function to protect the drive against ground faults in the motor and motor cable. This function is not a personnel safety or a fire protection feature. See the firmware manual for more information.

Residual current device compatibility

The drive is suitable to be used with residual current devices of Type B.

Note:

As standard, the drive contains capacitors connected between the main circuit and the frame. These capacitors and long motor cables increase the ground leakage current and may cause nuisance faults in circuit breakers.

Implementing the Emergency stop function

For safety reasons, install the emergency stop devices at each operator control station and at other operating stations where emergency stop may be needed. Implement the emergency stop according to relevant standards.

■ Cabinet-installed multidrives

You can order the drive with an emergency stop function.

See the appropriate manual for more information.

Name	Code
Emergency stop, stop category 0 (option +Q951) for ACS880 multidrives user's manual	3AUA0000119885
Emergency stop, stop category 1 (option +Q952) for ACS880 multidrives user's manual	3AUA0000119886
Emergency stop, stop category 0 (option +Q963) for ACS880 multidrives user's manual	3AUA0000119891

Name	Code
Emergency stop, stop category 1 (option +Q964) for ACS880 multidrives user's manual	3AUA0000119893
Emergency stop, configurable stop category 0 or 1 (option +Q979) for ACS880 multidrives user's manual	3AUA0000145933

■ Multidrive modules

For safety reasons, install the emergency stop devices at each operator control station and at other operating stations where emergency stop may be needed. Implement the emergency stop according to relevant standards.

You can use the Safe torque off function of the drive (inverter unit) to implement the Emergency stop function.

Implementing the Safe torque off function

The safe torque off (STO) input is available as standard in all inverter units. See the inverter unit hardware manual for implementing the Safe torque off function.

Implementing the Prevention of unexpected start-up function

■ Cabinet-installed multidrives

You can order the drive with a Prevention of unexpected start-up (POUS) function. The POUS function enables short-time maintenance work (like cleaning) on the non-electrical parts of the machinery without switching off and disconnecting the drive.

See the appropriate manual for more information.

Name	Code
Prevention of unexpected start-up (option +Q957) for ACS880 multidrives user's manual	3AUA0000119894
Prevention of unexpected start-up (option +Q950) for ACS880 multidrives user's manual	3AUA0000145934

■ Multidrive modules

POUS is not available as an option from ABB.

Implementing the Safely-limited speed function

■ Cabinet-installed multidrives

You can order the drive with Safely-limited speed function (option +Q966). It enables the user to safely operate close to the machine at low speed, without stopping it.

See the appropriate manual for more information.

Name	Code
Safely-limited speed without the encoder interface (option +Q966) for ACS880 multidrives user's manual	3AUA0000145935
Safely-limited speed with the encoder interface (option +Q965) for ACS880 multidrives user's manual	3AXD50000019728

■ Multidrive modules

Safely-limited speed function is not available as an option from ABB. However, the cabinet builder can implement it with an optional safety module available from ABB. See [Implementing the functions provided by the FSO-xx safety functions module \(page 36\)](#).

Implementing the functions provided by the FSO-xx safety functions module

■ Cabinet-installed multidrives

You can order the drive with an FSO-12 or FSO-21 safety functions module (option +Q972 or +Q973) which enables the implementation of functions such as Safe brake control (SBC), Safe stop 1 (SS1), Safe stop emergency (SSE), Safely limited speed (SLS) and Safe maximum speed (SMS).

The settings of the FSO-xx module are at default when delivered from the factory. The wiring of the external safety circuit and configuration of the FSO-xx module are the responsibility of the user.

The FSO-xx module reserves the standard Safe torque off (STO) connection of the inverter control unit. STO can still be utilized by other safety circuits through the FSO-xx.

See the appropriate manual for more information.

Name	Code
FSO-12 safety functions module user's manual	3AXD50000015612
FSO-21 safety functions module user's manual	3AXD50000015614

■ Multidrive modules

You can order a safety function module from ABB. The cabinet builder can use the module for implementing various safety functions.

Supplying power for the auxiliary circuits

■ Cabinet-installed multidrives

The drive is equipped with an auxiliary voltage transformer which supplies, for example, control unit(s) and cooling fan(s).

The user must supply these options from external power sources:

- +G300/+G301: Cabinet heaters and/or lighting (230 or 115 V AC; external fuse: 16 A gG)
- +G307: Connection for an external uninterruptible power supply (230 or 115 V AC; external fuse 16 A gG)
- +G313: Power supply connection for a motor space heater output (230 V AC; external fuse 16 A gG).

■ Multidrive modules

The cabinet installer must connect an auxiliary power supply for the drive. Auxiliary power is needed, for example, by the control units and cabinet fan(s). See the appropriate hardware manuals for the auxiliary power consumptions, connections, etc.

Using power factor compensation capacitors with the drive

Power factor compensation is not needed with AC drives. However, if a drive is to be connected in a system with compensation capacitors installed, note the following restrictions.



WARNING!

Do not connect power factor compensation capacitors or harmonic filters to the motor cables (between the drive and the motor). They are not meant to be used with AC drives and can cause permanent damage to the drive or themselves.

If there are power factor compensation capacitors in parallel with the input of the drive:

1. Do not connect a high-power capacitor to the power line while the drive is connected. The connection will cause voltage transients that may trip or even damage the drive.
2. If capacitor load is increased/decreased step by step when the AC drive is connected to the power line, make sure that the connection steps are low enough not to cause voltage transients that would trip the drive.
3. Check that the power factor compensation unit is suitable for use in systems with AC drives, ie, harmonic generating loads. In such systems, the compensation unit should typically be equipped with a blocking reactor or harmonic filter.

Using a safety switch between the drive and the motor

ABB recommends to install a safety switch between the permanent magnet motor and the drive output. The switch is needed to isolate the motor during any maintenance work on the drive.

Implementing the Power-loss ride-through function

Implement the power-loss ride-through function as follows:

- Check that the power-loss ride-through function of the drive (inverter unit) is enabled. See the drive firmware manual.
 - Make sure that the control of the main contactor/breaker either keeps the contactor closed over the short power break, or closes it after the break automatically.
-



WARNING!

Make sure that the automatic re-connection of the input power does not cause any danger. If you are in doubt, do not implement the Power-loss ride-through function.

Implementing the control of a contactor between drive and motor

The control of the output contactor depends on how you use the drive, that is, which motor control mode and which motor stop mode you select.

When you select the DTC motor control mode and the motor ramp stop mode, use this operation sequence to open the contactor:

1. Give a stop command to the drive.
 2. Wait until the drive decelerates the motor to zero speed.
 3. Open the contactor.
-



WARNING!

If DTC motor control mode is in use, do not open the output contactor while the drive controls the motor. The motor control operates faster than the contactor, and tries to maintain the load current. This can cause damage to the contactor.

When you select the DTC motor control mode and the motor coast stop mode, you can open the contactor immediately after the drive has received the stop command. This is the case also if you use the scalar motor control mode.

Implementing a bypass connection

If bypassing is required, employ mechanically or electrically interlocked contactors between the motor and the drive and between the motor and the power line. Make sure with interlocking that the contactors cannot be closed simultaneously. The installation must be clearly marked as defined in IEC/EN 61800-5-1, subclause 6.5.3, for example, "THIS MACHINE STARTS AUTOMATICALLY".

Bypass connection is available as a factory-installed option for some cabinet-installed drive types. Consult ABB for more information.



WARNING!

Never connect the drive output to the electrical power network. The connection may damage the drive.

Protecting the contacts of relay outputs

Inductive loads (relays, contactors, motors) cause voltage transients when switched off.

The relay contacts on the drive control unit are protected with varistors (250 V) against overvoltage peaks. In spite of this, it is highly recommended that inductive loads are equipped with noise attenuating circuits (varistors, RC filters [AC] or diodes [DC]) to minimize the EMC emission at switch-off. If not suppressed, the disturbances may connect capacitively or inductively to other conductors in the control cable and form a risk of malfunction in other parts of the system.

Install the protective component as close to the inductive load as possible. Do not install protective components at the relay outputs.

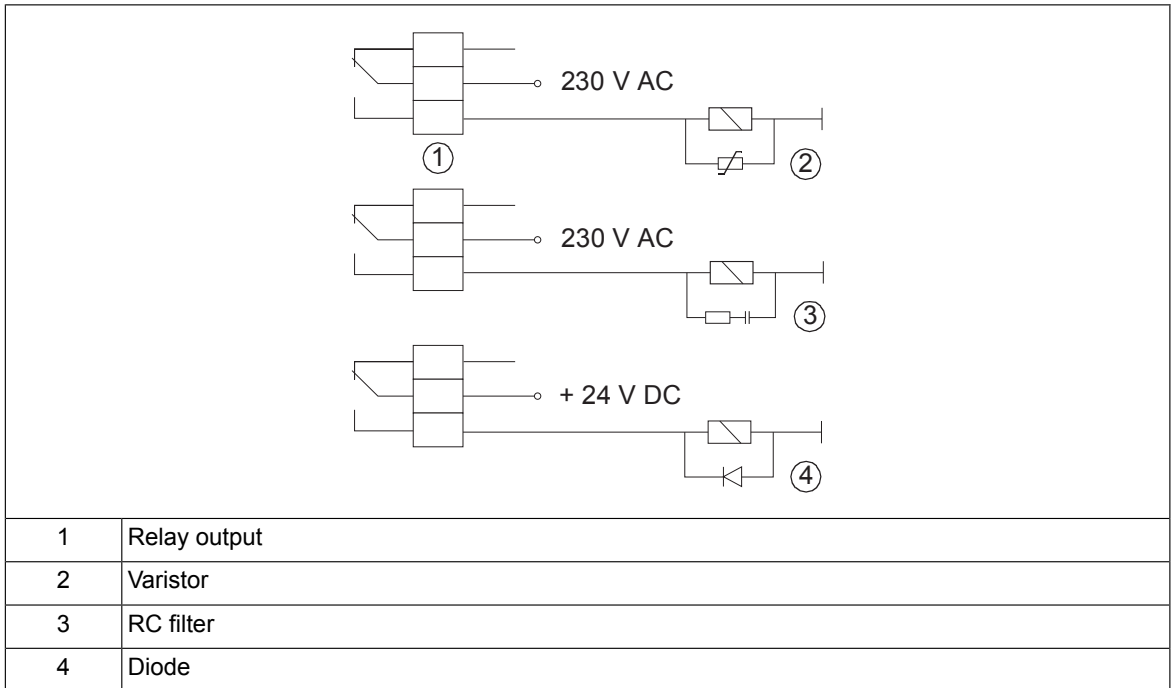



Standards and markings

Contents of this chapter

The chapter contains a list of applicable standards, a list of markings, compliance information (European directives) and the disclaimers.





Applicable standards

EN 61800-5-1:2007	Adjustable speed electrical power drive systems - Part 5-1: Safety requirements - Electrical, thermal and energy
EN 60204-1: 2016	Safety of machinery - Electrical equipment of machines - Part 1: General requirements
EN 61800-3:2004 + A1:2012	Adjustable speed electrical power drive systems - Part 3: EMC requirements and specific test methods
EN 61800-5-2:2016	Adjustable speed electrical power drive systems - Part 5-2: Safety requirements – Functional
EN 62061:2005 + AC:2010 + A1:2013 + A2:2015	Safety of machinery - Functional safety of safety-related electrical, electronic and programmable electronic control systems
EN ISO 13849-1:2015	Safety of machinery - Safety-related parts of control systems - Part 1: General principles for design
EN ISO 13849-2:2012	Safety of machinery - Safety-related parts of control systems - Part 2: Validation
IEC 61508 ed.2: 2010	Functional safety of electrical /electronic / programmable electronics safety-related systems
IEC 60146-1-1:2009, EN 60146-1-1:2010	Semiconductor converters - General requirements and line commutated converters - Part 1-1: Specification on basic requirements
IEC/EN 60664-1:2007	Insulation coordination for equipment within low-voltage systems - Part 1: Principles, requirements and tests
IEC 60529:1989/A2:2013, EN 60529:1991/A2:2013	Degrees of protection provided by enclosures (IP code)

42 Standards and markings

IEC 61439-1:2011, EN 61439-1:2011	Low-voltage switchgear and controlgear assemblies - Part 1: General rules
IEC 61326-3-1:2008	Electrical equipment for measurement, control and laboratory use - EMC requirements - Part 3-1: Immunity requirements for safety-related systems and for equipment intended to perform safety-related functions (functional safety) - General industrial applications
IEC60533:2015	Electrical and electronic installations in ships - Electromagnetic compatibility (EMC) - Ships with a metallic hull

Markings

	<p>CE mark</p> <p>Product complies with the applicable European Union legislation. For fulfilling the EMC requirements, see the additional information concerning the drive EMC compliance (IEC/EN 61800-3).</p>
	<p>EAC (Eurasian Conformity) mark</p> <p>Product complies with the technical regulations of the Eurasian Customs Union. EAC mark is required in Russia, Belarus and Kazakhstan.</p>
	<p>WEEE mark</p> <p>At the end of life the product should enter the recycling system at an appropriate collection point and not placed in the normal waste stream.</p>
	<p>TÜV Nord Safety Approved mark (functional safety)</p> <p>Product contains Safe Torque Off and possibly other (optional) safety functions which are certified by TÜV Nord according to the relevant functional safety standards. Applicable to drives and inverters; not applicable to supply, brake or DC/DC converter units or modules.</p>

EMC compliance (IEC/EN 61800-3:2004 + A2012)

■ Definitions

EMC stands for Electromagnetic Compatibility. It is the ability of electrical/electronic equipment to operate without problems within an electromagnetic environment. Likewise, the equipment must not disturb or interfere with any other product or system within its locality.

First environment includes establishments connected to a low-voltage network which supplies buildings used for domestic purposes.

Second environment includes establishments connected to a network not supplying domestic premises.

Drive of category C2: drive of rated voltage less than 1000 V and intended to be installed and started up only by a professional when used in the first environment. **Note:** A professional is a person or organization having necessary skills in installing and/or starting up power drive systems, including their EMC aspects.

Drive of category C3: drive of rated voltage less than 1000 V and intended for use in the second environment and not intended for use in the first environment.

Drive of category C4: drive of rated voltage equal to or above 1000 V, or rated current equal to or above 400 A, or intended for use in complex systems in the second environment.

■ Category C3

The drive complies with the radiated emission limits of C3 category with these provisions:

1. The supply unit is C3-compliant:
 - Cabinet-installed multidrive: Supply unit is equipped with the filter option +E210.
 - Multidrive modules: Supply modules have the C3-compliant filtering installed as standard.
2. The motor and control cables are selected, and routed according to the electrical planning guidelines of the drive. The EMC recommendations are obeyed.
3. The drive is installed according to its installation instructions. The EMC recommendations are obeyed.
4. Motor cable length (for any inverter unit) does not exceed 100 meters (328 ft).
Note: ABB has done the type testing with a 100 meter (328 ft) cabling.



WARNING!

A drive of category C3 is not intended to be used on a low-voltage public network which supplies domestic premises. Radio frequency interference is expected if the drive is used on such a network.

■ Category C4

The drive complies with the C4 category with these provisions:

1. It is ensured that no excessive emission is propagated to neighboring low-voltage networks. In some cases, the natural suppression in transformers and cables is sufficient. If in doubt, the supply transformer with static screening between the primary and secondary windings can be used.
-

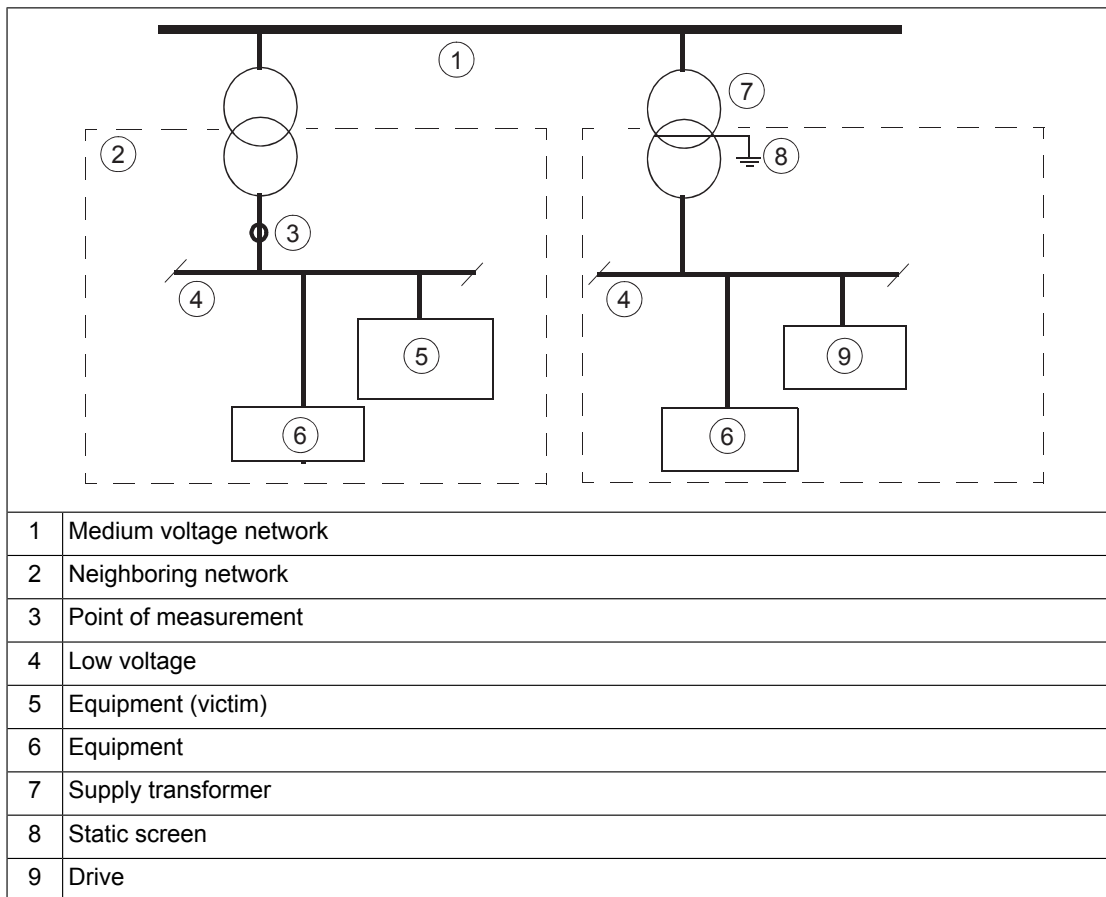

2. An EMC plan for preventing disturbances is drawn up for the installation. A template is available in *Technical guide No. 3 EMC compliant installation and configuration for a power drive system* (3AFE61348280 (English)).
3. The motor and control cables are selected, and routed according to the electrical planning guidelines of the drive. The EMC recommendations are obeyed.
4. The drive is installed according to its installation instructions. The EMC recommendations are obeyed.



WARNING!

A drive of category C4 is not intended to be used on a low-voltage public network which supplies domestic premises. Radio frequency interference is expected if the drive is used on such a network.

EU Declaration of Conformity (Machinery Directive)

■ Multidrive modules



EU Declaration of Conformity

Machinery Directive 2006/42/EC

We

Manufacturer: ABB Oy

Address: Hiomotie 13, 00380 Helsinki, Finland.

Phone: +358 10 22 11

declare under our sole responsibility that the following products:

Frequency converters and frequency converter components

ACS880-04, -14, -34 (frames nxR8i)

ACS880-04XT, -04FXT

ACS880-07, -17, -37

ACS880-104

ACS880 multidrives

ACS880-104LC (frames nxR8i)

ACS880-07CLC

identified with serial numbers beginning with 1 or 8

with regard to the safety functions

Safe torque off

Safe motor temperature with FPTC-01 module (option code +L536)

Safe stop 1, Safe stop emergency, Safely-limited speed, Safe maximum speed, Safe brake control, Prevention of unexpected start-up, with FSO-12 module (option code +Q973)

Safe stop 1, Safe stop emergency, Safely-limited speed, Safe maximum speed, Safe brake control, Safe Speed monitor, Safe direction, Prevention of unexpected start-up, with FSO-21 and FSE-31 modules (option codes +Q972 and +L521)

ACS880-07, -17, -37, -07CLC and ACS880 multidrives: Prevention of unexpected start-up (option codes +Q950; +Q957), **Emergency stop** (option codes +Q951; +Q952; +Q963; +Q964; +Q978; +Q979), **Safely-limited speed** (option codes +Q965; Q966)

are in conformity with all the relevant safety component requirements of EU Machinery Directive 2006/42/EC, when the listed safety functions are used for safety component functionality.



The following harmonized standards have been applied:

EN 61800-5-2:2007	Adjustable speed electrical power drive systems – Part 5-2: Safety requirements - Functional
EN 62061:2005 + AC:2010 + A1:2013 + A2:2015	Safety of machinery – Functional safety of safety-related electrical, electronic and programmable electronic control systems
EN ISO 13849-1:2015	Safety of machinery – Safety-related parts of control systems. Part 1: General principles for design
EN ISO 13849-2:2012	Safety of machinery – Safety-related parts of the control systems. Part 2: Validation
EN 60204-1:2006 + A1:2009 + AC:2010	Safety of machinery – Electrical equipment of machines – Part 1: General requirements

The following other standard has been applied:

IEC 61508:2010, parts 1-2	Functional safety of electrical / electronic / programmable electronic safety-related systems
IEC 61800-5-2:2016	Adjustable speed electrical power drive systems – Part 5-2: Safety requirements - Functional

The products referred in this Declaration of conformity fulfil the relevant provisions of other European Union Directives which are notified in Single EU Declaration of conformity 3AXD10000497305.

Person authorized to compile the technical file:

Name and address: Vesa Tiihonen, Hiomotie 13, 00380 Helsinki, Finland

Helsinki, 11 Apr 2019

Manufacturer representative:



Peter Lindgren
Vice President, ABB Oy

■ Cabinet-installed multidrives

The declaration of conformity is included in the drive delivery.

Approvals

Consult ABB.

Disclaimers

■ Generic disclaimer

The manufacturer shall have no obligation with respect to any product which (i) has been improperly repaired or altered; (ii) has been subjected to misuse, negligence or accident; (iii) has been used in a manner contrary to the manufacturer's instructions; or (iv) has failed as a result of ordinary wear and tear.

■ Cybersecurity disclaimer

This product is designed to be connected to and to communicate information and data via a network interface. It is Customer's sole responsibility to provide and continuously ensure a secure connection between the product and Customer network or any other network (as the case may be). Customer shall establish and maintain any appropriate measures (such as but not limited to the installation of firewalls, application of authentication measures, encryption of data, installation of anti-virus programs, etc) to protect the product, the network, its system and the interface against any kind of security breaches, unauthorized access, interference, intrusion, leakage and/or theft of data or information. ABB and its affiliates are not liable for damages and/or losses related to such security breaches, any unauthorized access, interference, intrusion, leakage and/or theft of data or information.

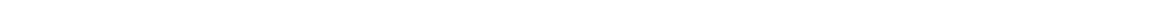

Further information

Product and service inquiries

Address any inquiries about the product to your local ABB representative, quoting the type designation and serial number of the unit in question. A listing of ABB sales, support and service contacts can be found by navigating to www.abb.com/searchchannels.

Product training

For information on ABB product training, navigate to new.abb.com/service/training.

Providing feedback on ABB manuals

Your comments on our manuals are welcome. Navigate to new.abb.com/drives/manuals-feedback-form.

Document library on the Internet

You can find manuals and other product documents in PDF format on the Internet at www.abb.com/drives/documents.



www.abb.com/drives



3AXD50000048634C